

MaxMotion

Date: 2020-03-10

PERFORMANCE DATA SHEET

Meets or exceeds MEPS (Minimum Efficiency Performance Standards), as described by the US Department of Energy in docket 10CFR431 and Natural Resources Canada's Amendment 14

Catalogue #: MPR-132CH

HP	kW	Voltage	S.F. @ 60Hz	EFF.	P.F.	Frame	Design	L.R. Amps
0.33	0.25	575	1.15	62.8%	0.700	56HC	B	5

60 Hz								Code	F.L. RPM
FLA									
208	230	416	460	480	575	600			
/	/	/	/	/	0.57	/	L	3470	

50 Hz								
HP	kW	FLA		S.F. @ 50Hz	Efficiency	P.F.	Code	F.L. RPM
		190	380					
/	-	/	/	/	/	/	/	/

Wgt. Lbs	PH	Duty	Insul. Class	Amb.	Elevation	Temp. Rise° C
21	3	Cont.	F	40°C	1000M (3,300 Ft)	34

% Efficiency		% Power Factor		Torque		Winding Resist. Ω	Safe Cold Start (Secs)
Full Load:	62.8%	Full Load:	0.70	Full Load Ft/Lbs	0.5		
3/4 Load:	56.2%	3/4 Load:	0.64	Locked Rotor %	416		
1/2 Load:	45.9%	1/2 Load:	0.57	Break Down %	443	80.1	12

Rotor Inertia Wk2 Lb-Ft2	Max Load Inertia Wk2 Lb-Ft2	Shaft Material	Frame Material	DE Bracket Type	ODE Bracket Type	Enclosure	NEMA Rating	Lead Wire Size
/	/	Steel	Rolled Steel	Aluminium Alloy		TEFC	IP55	0

Ball Bearings		Grease	Mount Type	Orientation	Paint	Sound Pressure @ 3FT	Sound Power
DE	ODE						
6205	6203	Sealed Bearings	Rigid	Horizontal	Grey	52	/

Inverter Duty. Motor meets MG1 parts 31.4.4.2	Constant Torque Range	Variable Torque Range	Constant HP RPM
		10:1	20:1

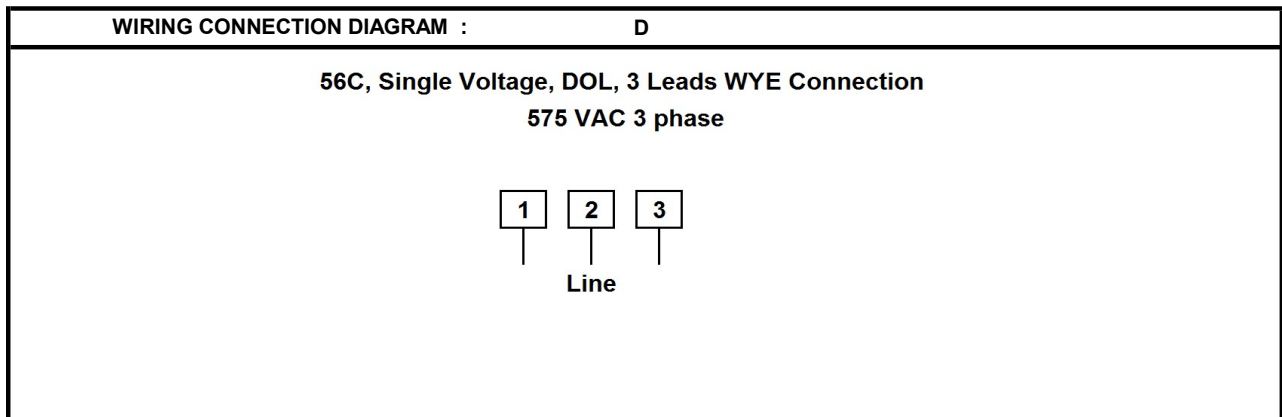

Date: 2020-03-10
 Customer: _____
 Contact: _____
 Submittee: J.C. Lavallée

Catalogue #: **MPR-132CH**

Meets or exceeds MEPS (Minimum Efficiency Performance Standards), as described by the US Department of Energy in docket 10CFR431 and Natural Resources Canada's Amendment 14

HP	VAC	RPM	Enclosure	Frame	Frequency	Design	Poles	LR Code Letter	Insulation Class	Temp. Rise °C
0.33	575	3470	TEFC	56HC	60	B	2	L	F	34
	0Hz	6Hz	15Hz	30Hz	45Hz	60Hz	75Hz	90Hz	105Hz	120Hz
Amps	0.57	0.57	0.57	0.57	0.57	0.57	0.57	0.57	0.57	0.57
RPM	0	347	867.5	1735	2602.5	3470	4337.5	5205	6072.5	6940
Torq ft.lb	0.40	0.40	0.50	0.50	0.50	0.50	0.40	0.33	0.29	0.25
Peak Tq ft.lb	0.80	1.61	1.61	1.61	1.61	1.61	1.28	1.07	0.92	0.80
HP	0	0.0	0.1	0.2	0.2	0.3	0.3	0.3	0.3	0.3
	Locked Rotor	Pull-Up	Breakdown	Rated Load	Idle	Duty	S. F.	Ambient	Elevation	dBA @ 1M
Speed (RPM)	0.0	1512	2880	3470	3600	Continuous	1.15	40°C	3,300 ft	52
Current (Amps)	5.0	4.3	3.0	0.6	0.4	VFD Rating: Meets MG1 parts 31.4.4.2				
Torque (ft.-lbs)	2.1	1.8	2.2	0.5	0.0	C.T.	10:1	V.T.	20:1	

Motor Speed Data

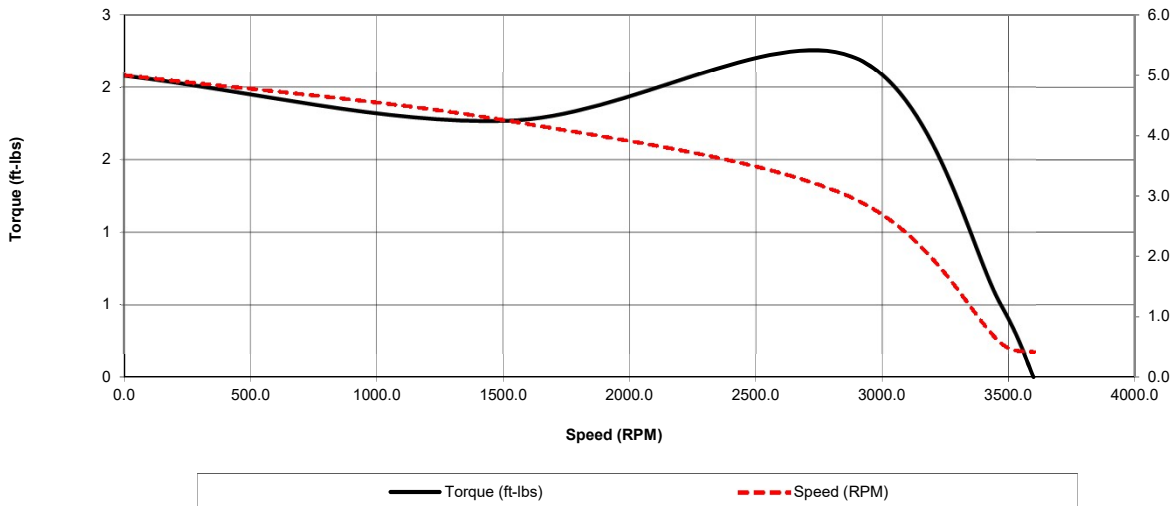

Motor Torque Capability vs RPM

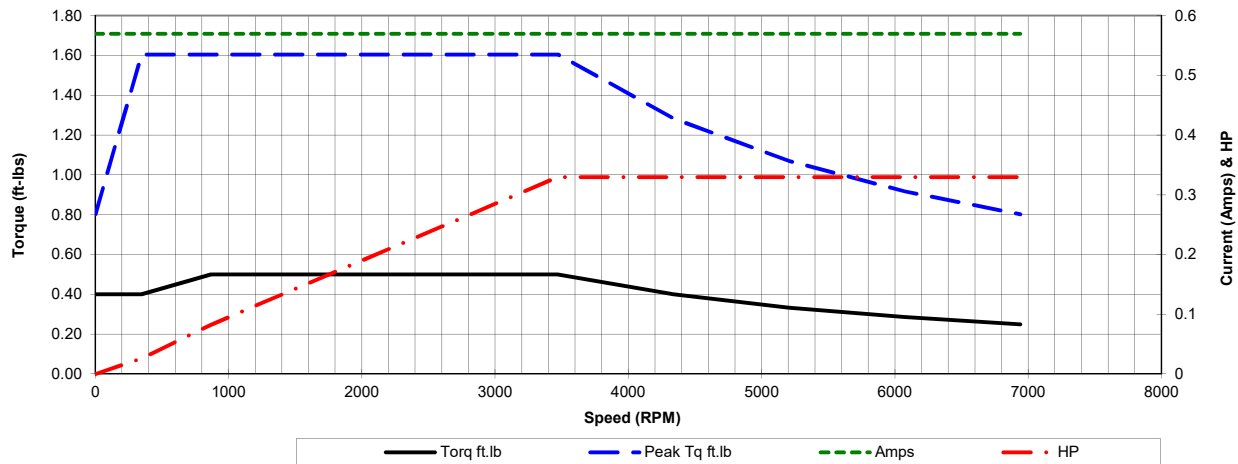



Date: 2020-03-10
 Customer: _____
 Contact: _____
 Submittee: J.C. Lavallée

Catalogue #: **MPR-132CH**

Meets or exceeds MEPS (Minimum Efficiency Performance Standards), as described by the US Department of Energy in docket 10CFR431 and Natural Resources Canada's Amendment 14										
HP	VAC	RPM	Enclosure	Frame	Frequency	Design	Poles	LR Code Letter	Insulation Class	Temp. Rise °C
0.33	575	3470	TEFC	56HC	60	B	2	L	F	34

Load %	0%	25%	50%	75%	100%	125%	150%
Amps	0.43	0.45	0.49	0.52	0.57	0.71	0.86
Torq ft/lbs	0	0.12	0.25	0.37	0.50	0.63	0.76
RPM	0	3567.5	3535	3502.5	3470	3437.5	3405
Eff	0	30.25	44.71	55.60	62.80	60.74	59.00
PF	0	45.0	57	64	70.0	71.4	73.5

	Locked Rotor	Pull-Up	Breakdown	Rated Load	Idle	Duty	S. F.	Ambient	Elevation	dBa @ 1M
Speed (RPM)	0	1512	2880	3470	3600	Continuous	1.15	40°C	3,300 ft	52
Current (Amps)	5	4.3	3.0	0.57	0.426	VFD Rating: Meets MG1 parts 31.4.4.2				
Torque (ft-lbs)	2.08	1.77	2.21	0.50	0.0	C.T.	10:1	V.T.	20:1	

